

UM4BG1TCX

ISUZU

ISUZU MOTORS ENGINE SALES INC.

UM4BG1TCX

DIMENSIONS (mm)

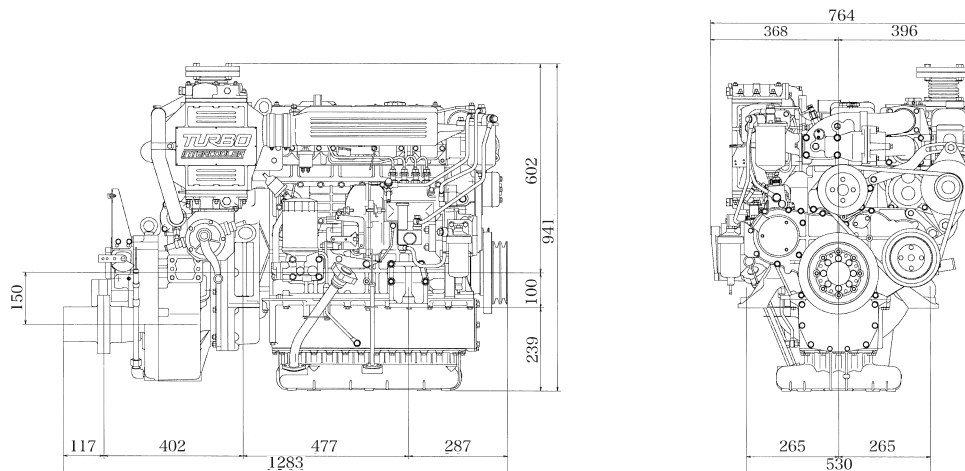

PERFORMANCE CURVES

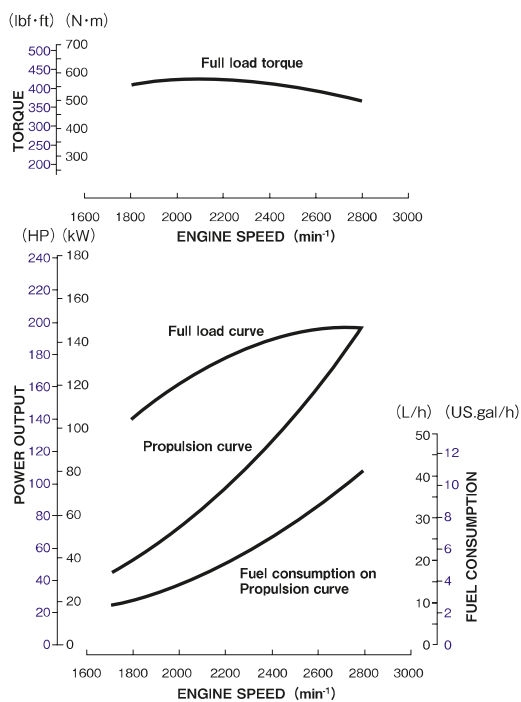

ENGINE SPECIFICATIONS

Configuration	4-cylinder, vertical in-line, 4-cycle diesel engine		
Bore x Stroke	mm (in)	105 x 125 (4.13 x 4.92)	
Displacement	Lit. (cid)	4.329 (264)	
Rated output	kW(PS)/min ⁻¹	Medium duty	134 (182) / 2700
		Light duty	147 (200) / 2800
Application	Commercial use		
Governor type	Mechanical		
Combustion type	Direct injection		
Aspiration	Turbo charged / Intercooler		
Exhaust gas status	IMO Tier II		
Engine weight	kg (lb)	Engine	515(1,135)
		with MGN35A-1	668(1,473)
Fuel used	Diesel fuel		
Starter	V-kW	24 - 4.5	
Alternator	V-A	24 - 50	
Lubrication method	Full flow pressure circulation		
Cooling method	Freshwater, full flow pressure circulation (Seawater, indirect)		
Heat exchanger (seawater circulation)	Multi-tube type (freshwater→seawater)		
Intercooler	Multi-tube type (seawater circulation)		
Rotation direction	Crankshaft	Right (clockwise) viewed from front of engine	
	Propeller shaft	Right (clockwise) viewed from stern	
Idling speed	min ⁻¹	550	
Marine gear	Marine Gear Model	MGN35A-1	
	Clutch type	Wet, Multi-plate hydraulic type	
	Reverse type	Constant-mesh type gear	
	Reduction ratio	2.56, 3.05, 3.45	

Specifications subject to change without notice

ACCESSORIES

Standard

- Installation kit
- Battery relay
- Extension harness (3m)
- Seawater pump impeller *
- Bilge pump
- Control head
- Instrument panel
- Oil drain pump
- Blow-by pipe
- Tool kit
- Owner's manual

* spare parts

Option

- Extension harness (3m)
- Control cable (4m,6m,10m,12m)
- Stop cable (4m,6m,8m)
- Kingston valve

ISUZU MOTORS ENGINE SALES INC.

